

Division Procedure: Vegetation Management Plan CEOP8008

Essential Energy's bushfire priority zones and associated risk controls are currently being revised and tested. Information contained within this document may not be reflective of current practice. For more information, review Annexure C of CEOP8067 or contact the Document Owner.

If working from a printed copy of this document, check Policy Alerts and the Policy Library regularly for updates.

24 October 2024 – Issue 16
Approved By: Asset Management and Regulatory Strategy Manager
Next review date: October 2027
OFFICIAL

CONTENTS

1.0	PURPOSE.....	4
1.1	Audience	4
2.0	CONSULTATION.....	4
3.0	RISK MANAGEMENT.....	5
3.1	Forms of vegetation-related electricity network risk.....	6
3.2	Risk controls for mitigating vegetation-related electricity network risks	6
3.2.1	<i>Assessment of alternative options to pruning</i>	7
3.3	Safe working near the electricity network.....	7
3.4	Hazard management cycles	7
3.5	Prioritisation of hazard remediation.....	8
3.5.1	<i>Bushfire Danger Period Preparedness</i>	8
4.0	VEGETATION MANAGEMENT PROGRAM DESIGN	9
4.1	Differences in approach between urban and rural areas	9
4.2	Minimum Clearing Requirements	10
4.3	Minimum Vegetation Clearance Zone.....	11
4.3.1	<i>Risk-Based Approach to Minimum Vegetation Clearance Dimensions</i>	12
4.3.2	<i>Tolerable Risk Vegetation</i>	12
4.3.3	<i>Significant Vegetation</i>	13
4.4	Regrowth Allowance.....	13
4.5	Low Growing Vegetation Zone.....	13
4.6	Fall-In Risk Management Zone.....	13
4.7	Overhang Risk Management Zone	14
4.8	Vegetation Corridor Management.....	14
4.9	Privately Owned Electricity Lines.....	15
4.10	Network within jurisdictions other than New South Wales.....	15
5.0	MINIMUM VEGETATION CLEARANCE DIMENSIONS.....	16
5.1	Minimum Vegetation Clearances (in metres) for span lengths 0m to 300 m in NSW, QLD & VIC	16
5.2	Minimum Vegetation Clearances (in metres) for span lengths 0m to 300m within the ACT 17	
5.3	Minimum Vegetation Clearances (in metres) for span lengths 300m to 600m within all jurisdictions	17
5.4	Fenced Assets	19
5.5	Padmount Substations and Switching Cubicles	19
5.6	Stays, Poles and Towers	20
5.7	Water Crossings	21
5.8	Public Lighting Clearances	21
6.0	VEGETATION MANAGEMENT METHODS.....	22
6.1	Vegetation Inspection and Scoping	22



6.1.1	<i>Integrated Vegetation Management</i>	22
6.1.2	<i>Biosecurity and organic property considerations</i>	22
6.1.3	<i>Environment and heritage considerations</i>	22
6.2	Pruning.....	23
6.3	Tree Removal	23
6.4	Tree Height Reduction.....	24
6.5	Herbicide Application.....	24
6.6	Vegetation growth regulators	25
6.7	Non-chemical applications.....	25
6.8	Debris management.....	25
7.0	STAKEHOLDER ENGAGEMENT.....	25
7.1	Notification.....	25
7.1.1	<i>Notification prior to conducting routine Vegetation Inspection or Treatment</i> ..	26
7.1.2	<i>Consultation on proposed Vegetation Treatment methods</i>	26
7.1.3	<i>Urgent or Emergency Vegetation Inspection or Treatment</i>	26
7.1.4	<i>Written notice to give direction to undertake bushfire mitigation work</i>	26
7.2	Landholder Queries and Complaints.....	26
7.3	Councils	27
7.4	NSW National Parks and Wildlife Service	27
7.5	Forestry Corporation NSW.....	27
7.6	Australian Rail Track Corporation and UGL Regional Linx	27
7.7	Australian Macadamia Society	27
8.0	TREE PLANTING GUIDELINES.....	28
8.1	Tree planting on private land.....	28
8.2	Council (street) tree plantings	28
8.2.1	<i>Trees Unsuitable for Planting Under or Near Powerlines</i>	29
8.3	Commercial tree plantations (includes State Forests, private forestry, and orchards) 29	
9.0	AUTHORITIES AND RESPONSIBILITIES.....	29
10.0	DEFINITIONS	30
11.0	REFERENCES.....	32
12.0	REVISIONS.....	33



OFFICIAL**1.0 PURPOSE**

This Vegetation Management Plan describes Essential Energy's approach to the following vegetation management considerations:

- vegetation management program design;
- vegetation management methods;
- clearance distances required between vegetation and electrical assets;
- sharing responsibilities for vegetation related electrical safety risk;
- environmental management;
- emergency management;
- customer engagement; and
- public education.

This Vegetation Management Plan represents Essential Energy's formal instrument for the following requirements:

- 'Tree Management Plan' as required by New South Wales (NSW) Electricity Supply (Safety and Network Management) Regulation 2014
- Vegetation Management (Bushfire and Environmental) Works Plan (Works Plan) as required by the Australian Capital Territory (ACT) Electricity (Powerline Vegetation Management) Code 2018.

1.1 Audience

This procedure is intended for all employees of the Company, including but not limited to executives, managers, staff, contractors, and third-party resources.

2.0 CONSULTATION

Before finalising any major revision of this plan, Essential Energy consult with relevant Councils, various land management agencies and Essential Energy's Customer Advisory Group (who represent local communities).

Landholders are provided with notice and ability to discuss the proposed vegetation management practices in advance of when work is undertaken on their property. This plan is also made available to the public via the Essential Energy website and on request by calling 13 23 91.

Feedback on this plan from any interested parties is always welcome and should be addressed to:

Vegetation Strategy Manager

P.O. Box 5730, Port Macquarie NSW 2444

Telephone: 13 23 91

Email: vegetation@essentialenergy.com.au



3.0 RISK MANAGEMENT

Essential Energy is obligated to minimise risks related to operation of its electrical network so far as is reasonably practicable (SFAIRP), as per a comprehensive Commonwealth, State and Territory legislative and regulatory framework.

NSW *Electricity Supply Act 1995 Section 48 – Interference with electricity works by trees* contains requirements for maintaining vegetation and powers of an electricity network operator to ensure vegetation does not cause interference with electricity assets.

NSW *Electricity Supply (Safety and Network Management) Regulation 2014* requires Essential Energy to operate the network within an Electricity Network Safety Management System (ENSMS) framework in accordance with Australian Standard AS 5577 'Electricity network safety management systems'.

The ENSMS requires that Formal Safety Assessments (FSA) be undertaken to address the safety risks associated with the operation of the network to workers, the public (including public workers), property and environment. The Bushfire FSA identifies vegetation as a threat scenario and the management of vegetation as a critical preventative control in the management of bushfire risk.

Two mandated industry codes 'ISSC3 Guide for the Management of Vegetation in the Vicinity of Electricity Assets' (ISSC3) and 'Code of Practice: Electricity transmission and distribution asset management 2009' provide a basis for the expected vegetation management standards.

For network operated within the Australian Capital Territory (ACT), the Utilities (Technical Regulation) Act 2014 sets out technical requirements for energy utilities. The specific vegetation management requirements are set out in Division 5A.2 Vegetation Management under the Act.

This Vegetation Management Plan represents a part of Essential Energy's risk management documentation as per Figure 1 below.



Figure 1. Legislative requirements and documentation hierarchy

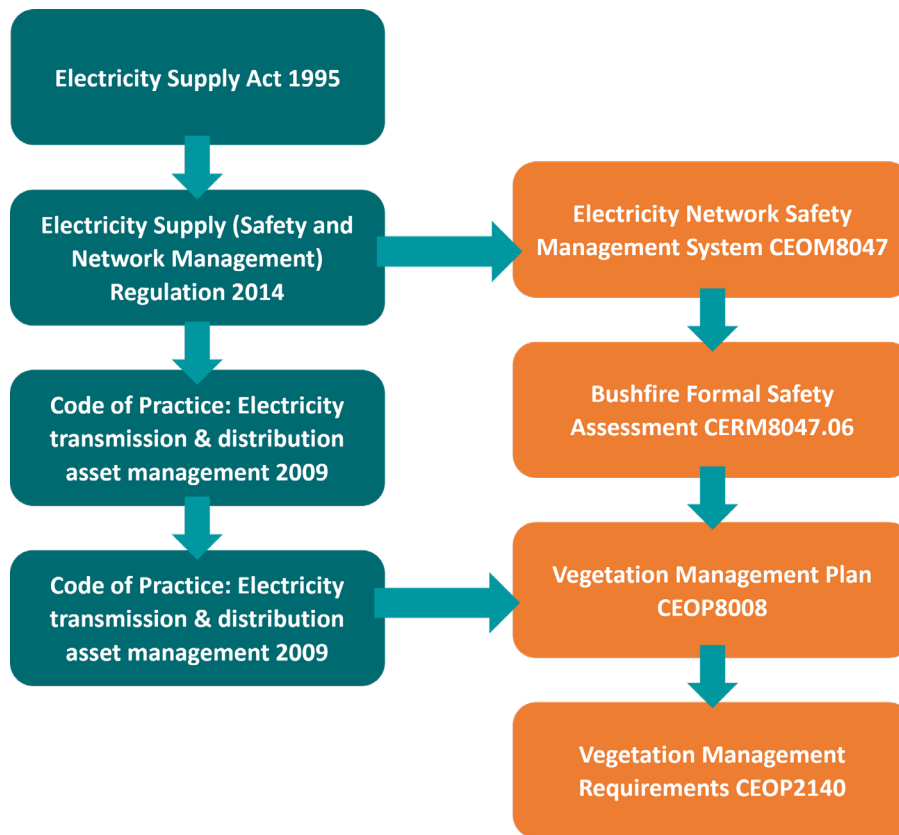

3.1 Forms of vegetation-related electricity network risk

Vegetation can pose a hazard to the safe operation of the electricity network in the form of grow-in, blow-in or fall-in hazards. Trees used by children to climb or play within may also be a hazard if located within proximity to the electricity network.

Consequences of contact between vegetation and the electricity network include, but are not limited to:

- Electric shock (sometimes referred to as ‘electrocution’) causing injury or death of a member of the public or officer representing Essential Energy;
- Bushfire ignition leading to loss of life and property; and
- Power outage causing loss of electricity supply to businesses, homes and critical infrastructure or facilities.

3.2 Risk controls for mitigating vegetation-related electricity network risks

Essential Energy focuses most of its efforts on preventing vegetation hazards from causing the consequences listed above. Risk controls are tailored to the assessed likelihood and consequence of vegetation impacting the electricity network. Vegetation-related risk controls include, but are not limited to:

- Routine ‘cyclic’ visual inspection of clearances between vegetation and the electricity network and condition of vegetation with fall-in potential;
- Vegetation treatment (pruning, removal, herbicide application, etc) to address offending vegetation identified during the routine cyclic inspection process;
- Annual aerial inspection and treatment of high bushfire priority areas for vegetation that may have grown too close to the network during the hazard management cycle, and fall-in vegetation that appears hazardous;



- Electricity network design;
- Electricity network operating protocols;
- Appropriate vegetation management standards and procedures;
- Appropriate worker qualifications, training, and competency;
- Auditing of completed inspections and treatment for adherence to standards and procedures;
- Education and communication channels for public awareness and reporting of vegetation hazards.

3.2.1 Assessment of alternative options to pruning

Alternative long-term measures for reducing the risk of ignitions and bushfires caused by vegetation near electricity assets are considered where known to be economically feasible and more environmentally sustainable than trimming in excess of minimum clearance distances.

Risk valuation is used when planning refurbishment of existing assets or installation of new assets, accounting for environmental, social and safety values. Costs and risks of continued vegetation management is considered in this valuation.

If required prior to planned network refurbishment, full or partial funding by landholders for conversion of overhead powerlines to aerial bundled conductor (ABC) or underground lines is possible.

3.3 Safe working near the electricity network

The trimming, cutting or removal of vegetation near electricity assets as required under this Plan must be done in a manner that protects the health and safety of persons performing inspection, trimming and removal activities.

Only authorised vegetation management workers may carry out work on vegetation near powerlines, that is, where any part of the vegetation is within 3m of a conductor or in cases where any branch overhangs conductors. All works performed are to be in accordance with the WorkCover NSW Work Near Overhead Power Lines Code of Practice 2006, chapter 5.

Authorised persons conducting Vegetation Inspection and Scoping are required to hold minimum qualifications which includes Certificate 3 in Arboriculture. Authorised persons conducting Vegetation Treatment are required to hold minimum qualifications including Certificate 2 in Electrical Supply Industry, encompassing safe practices and vegetation management techniques.

3.4 Hazard management cycles

The frequency of vegetation management is based on practical factors including vegetation regrowth rates, fire risk, climate, type of vegetation, recurrent costs, and conservation considerations. The time duration between routine vegetation management activities is referred to as the Hazard Management Cycle. Cycles are typically shorter in urban environments and longer in rural areas.

Hazard management cycle lengths are reviewed and adjusted as necessary for the purposes of risk management or in line with stakeholder needs.

It is acknowledged that vegetation does not grow at a linear rate due to environmental influences. At times, therefore, there may be vegetation that grows to a position inside the minimum vegetation clearance despite meeting the Minimum Clearance Requirement at the time of cutting. Notwithstanding this, the clear objective of the Hazard Management Cycle is to avoid any encroachment into the Minimum Vegetation Clearance between vegetation treatments as far as is reasonably practicable.



3.5 Prioritisation of hazard remediation

Essential Energy identifies and manages vegetation hazards in context of:

- assessed risk posed by the vegetation;
- bushfire risk priority rating;
- other hazard rectification priorities;
- operational efficiency; and
- community expectations and environmental amenity.

3.5.1 *Bushfire Danger Period Preparedness*

Essential Energy conducts aerial patrols of the electricity network within high bushfire risk areas each year in preparation for the Summer Bushfire Danger Period. Vegetation found within close proximity or deemed to be an immediate fall-in vegetation hazard to the overhead network is actioned prior to the start of the Bushfire Danger Period so far as is reasonably practicable.

Procedures are followed by Essential Energy staff and service providers to address the increased risk from vegetation hazards during the Bushfire Danger Period. These procedures restrict some activities during heightened fire weather conditions such as those experienced on Total Fire Ban days.



4.0 VEGETATION MANAGEMENT PROGRAM DESIGN

The Essential Energy network is assigned into five vegetation management regions. Figure 2 shows vegetation management regions and Essential Energy depot boundaries.

Figure 2. Essential Energy Network Area and Vegetation Management Regions.



4.1 Differences in approach between urban and rural areas

Essential Energy further divides its five vegetation management regions into around 3,900 Vegetation Management Areas (VMA) that represent logical groupings of similar risk and work types. Each VMA is classified as either ‘urban’ or ‘rural’ as per Essential Energy’s own definitions, attracting different hazard management cycles and vegetation treatment methods that are best suited to the setting. Procedures allow for tailored approaches in situations where a rural site exists in an urban VMA and where urban sites exist within a rural VMA.

Heightened bushfire risk and potentially longer power outage response times in rural areas require the use of vegetation management corridors. These corridors allow for reduced exposure to fall-in vegetation hazards as well as access to the electricity network.

Trees in urban areas can represent significant amenity value in the form of shade, appearance, cultural importance or to mitigate the effects of climate change through the development of an urban forest. As such, Essential Energy strives to balance this value with achieving its risk



management obligations. Electricity network design, more frequent hazard management cycles and tolerable risk-based exceptions to vegetation clearances are all employed where reasonably practicable. Trees that are incompatible with repeated pruning or cannot otherwise be managed in a reasonably practicable way to meet risk management obligations may require removal.

4.2 Minimum Clearing Requirements

Many factors affect the extent of vegetation treatment (otherwise referred to as ‘clearing’) including, but are not limited to, the length of the span, the conductor material, the amount of sag on hot days with heavily loaded lines, the amount of conductor swing, the degree of whip of adjacent trees on a windy day, the type of vegetation, vegetation regrowth rates, and the terrain.

As shown in Figure 3, Essential Energy applies Minimum Vegetation Clearances that utilise a simplified clearance envelope incorporating conductor movement, as per ISSC3.

Figure 3. Conductor movement and simplified clearance envelope

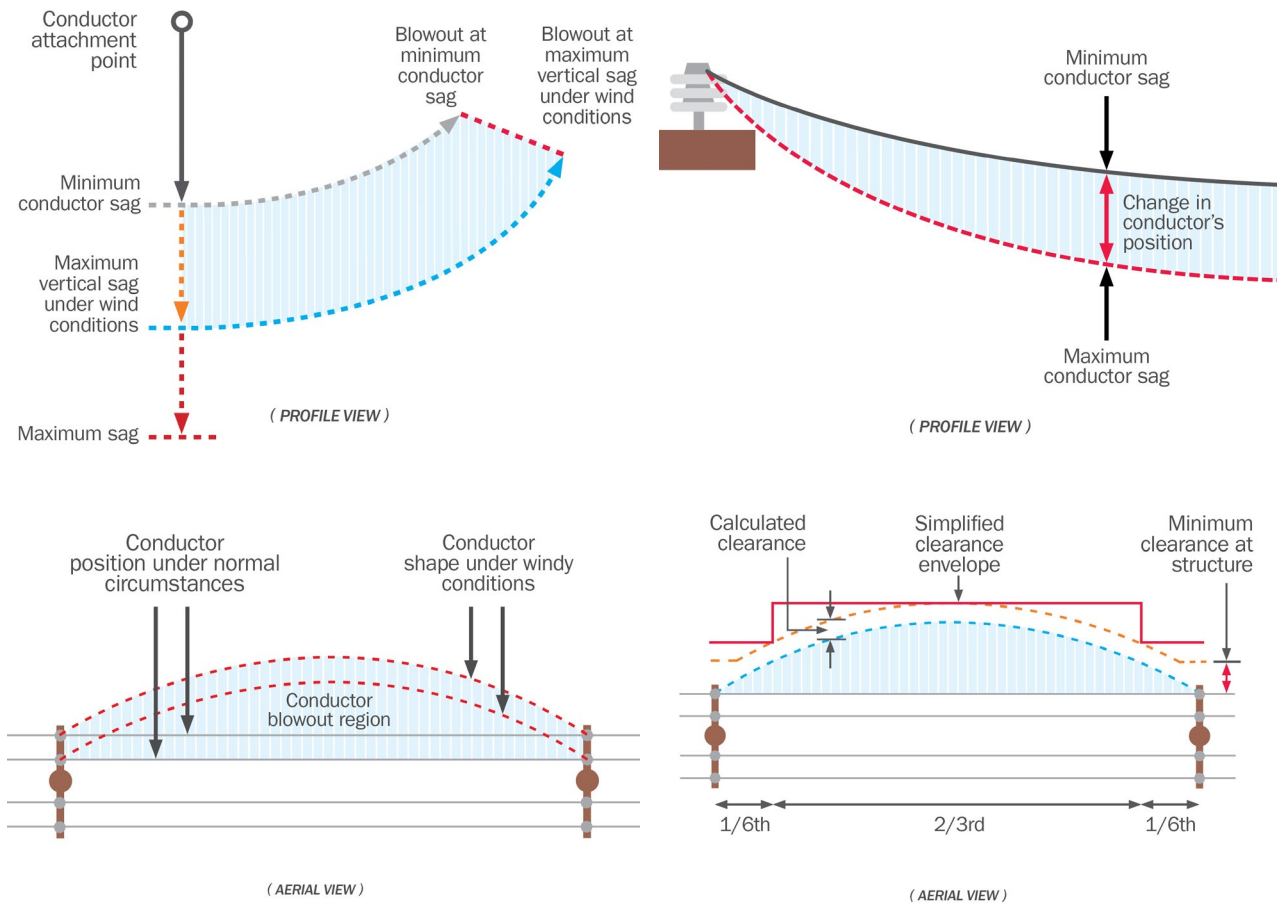

The Minimum Clearing Requirements are the sum of the Minimum Vegetation Clearance and the Regrowth Allowance as illustrated in Figures 4 and 5. At the time of completion of the Hazard Management Cycle remediation activities, the Minimum Clearing Requirement shall be achieved.



Figure 4. Simplified illustration of a rural vegetation management corridor

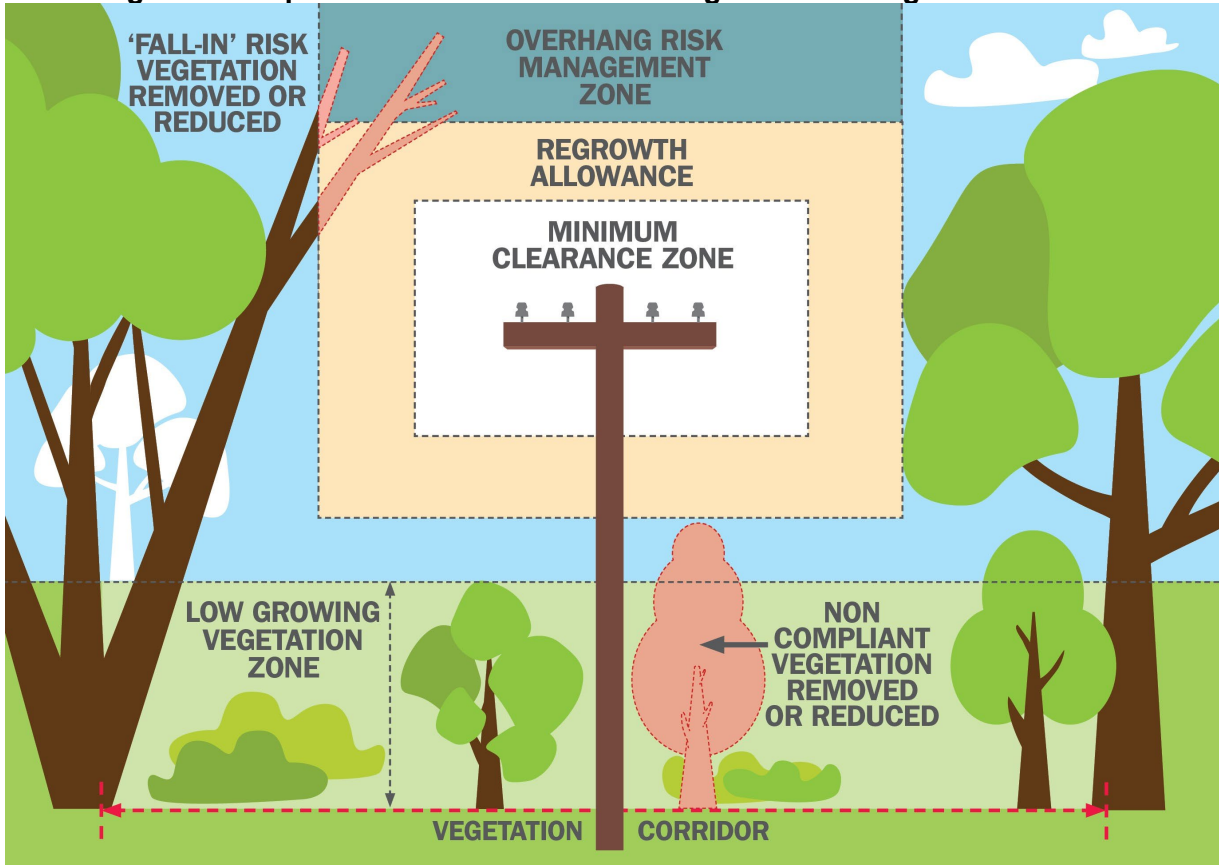
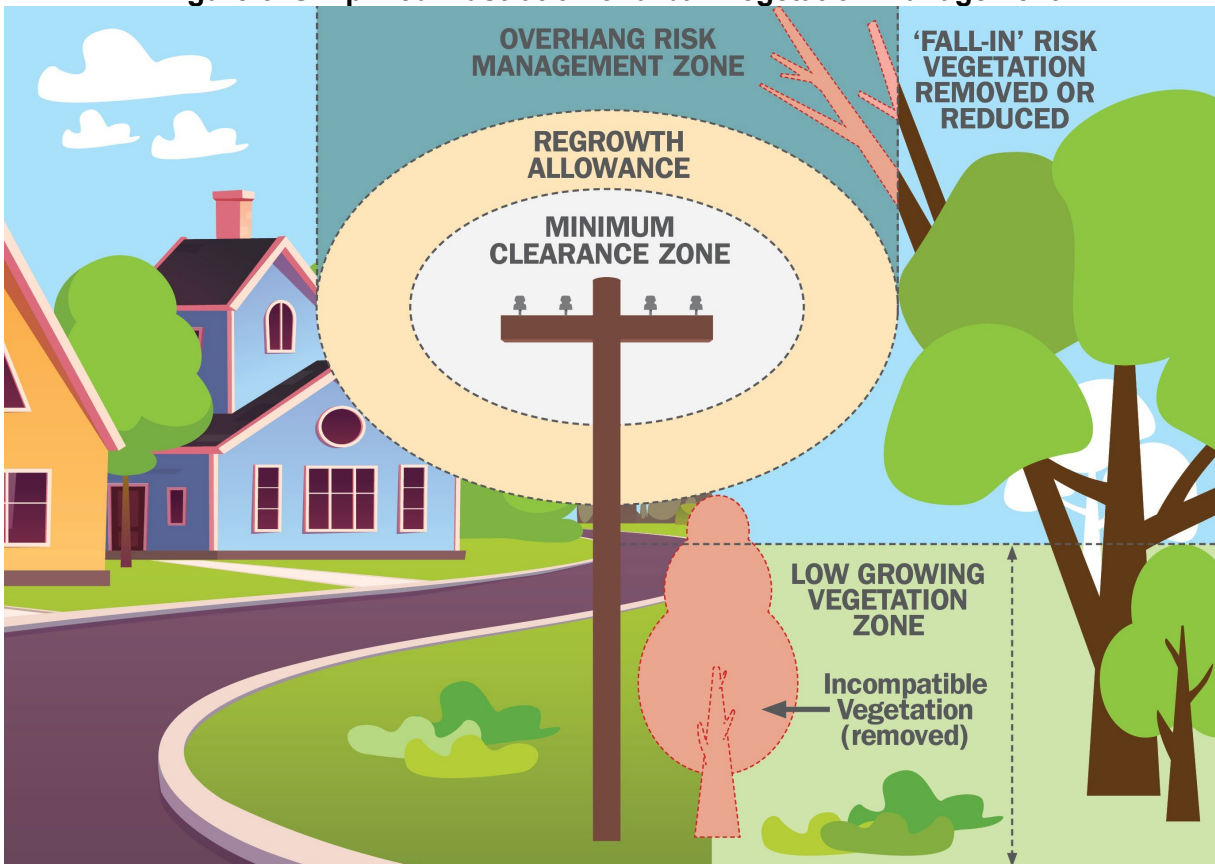

Figure 5. Simplified illustration of urban vegetation management



4.3 Minimum Vegetation Clearance Zone



The Minimum Vegetation Clearance Zone is the area surrounding the conductors defined by distances specified within **Section 5 Minimum Vegetation Clearance Dimensions**.

At time of Vegetation Treatment, all vegetation is to be removed from the Minimum Vegetation Clearance Zone unless it meets the criteria of an Exception as specified within this document.

4.3.1 Risk-Based Approach to Minimum Vegetation Clearance Dimensions

Essential Energy has nominated exceptions to the specified Minimum Vegetation Clearances based on assessment of risk associated with the proximity of Vegetation to Network Assets relevant to operational and environmental circumstances. These Exceptions are designed to manage Vegetation related risks so far as is reasonably practicable.

4.3.2 Tolerable Risk Vegetation

The Tolerable Risk Vegetation Exception is relative to the assigned Bushfire Risk Priority Rating.

Essential Energy or its nominated service provider assesses if Vegetation is Tolerable Risk Vegetation by carrying out a site-specific risk assessment based on the following risk assessment requirements:

- a) Tolerable Risk Vegetation Exceptions must only be considered in relation to Vegetation located within VMAs or Bays assigned a Bushfire Risk Priority Rating of P3 or P4;
- b) For uninsulated ('Bare') conductor types, the Vegetation must meet the following requirements, namely the Vegetation:
 - i) appears structurally sound and healthy;
 - ii) will not grow further than 25% into the Minimum Vegetation Clearance Zone during the Vegetation Management Cycle; and
 - iii) is not likely to contact HV overhead Network Assets (including via branch drop or loose bark).
- c) For insulated Low Voltage Mains, including overhead insulated Service Mains connecting a Premises to a LV overhead Network Asset, the Vegetation must meet the following requirements, namely the Vegetation:
 - i) appears structurally sound and healthy;
 - ii) is not, and is not likely to, during the Vegetation Management Cycle, to be visibly abrading, deviating, or preventing visual inspection of the Conductor; and
 - iii) is not otherwise damaging the Service Mains or any Premises.

The Exception does not apply if the risk assessment above shows that only part of the assessed Vegetation fits the criteria of Tolerable Risk Vegetation. For example, if a tree has two branches located inside the minimum clearance space, yet only one of those branches meets the criteria, neither branch nor other part of the tree qualifies for an exception. In this situation Essential Energy or the nominated service provider must carry out Vegetation Treatment on that Vegetation without applying the Tolerable Risk Vegetation Exception.



4.3.3 Significant Vegetation

Types of Trees or Vegetation considered as having community recognised significance include, but are not limited to, those existing within protected areas and/or on heritage registers, or otherwise protected by legal instrument.

During the Vegetation Inspection and Scoping process Essential Energy or its nominated service provider will consult with tree owners and stakeholders, where appropriate, to assist in the identification of Vegetation with community recognised significance. Personnel involved in performing Vegetation Treatment are made aware of the location of such Vegetation during pre-planning.

A more frequent Hazard Management Cycle or a mid-cycle inspection may be applied to such Vegetation, based on site-specific risk and hazard remediation priority.

4.4 Regrowth Allowance

The Regrowth Allowance is intended to account for growth of Vegetation towards the Minimum Vegetation Clearance Zone during the hazard management cycle. The dimension of the Regrowth Allowance is tailored to the expected growth habit of that Vegetation during the Hazard Management Cycle, as determined by a qualified person conducting vegetation inspection or treatment. Consideration is given to vegetation species, surrounding environmental conditions, local experience, and the significance of the Vegetation.

4.5 Low Growing Vegetation Zone

Low and slow-growing vegetation occurring below the Minimum Clearing Requirements is retained wherever reasonably practicable. Retention is achieved using target treatment of the saplings of fast-growing vegetation species, minimising site disturbance.

Mulching or other forms of disturbance of the Low Growing Vegetation Zone may be required to provide access to poles and other network assets. Where mulching is used, a follow-up selective foliar spray may be implemented to address sapling regrowth of any fast-growing Incompatible Vegetation.

It is essential that sapling regrowth of tall growing species are controlled before maturing to a point where more extensive works are required which is costly and resource intensive.

Where access tracks exist to inspect and maintain the electricity network, these are cleared of woody vegetation to assist heavy vehicle access.

4.6 Fall-In Risk Management Zone

In practice, many trees exist outside the minimum vegetation clearance zone at a height that if they were to fall, contact with an electricity asset could occur. It is not environmentally appropriate, economical, nor practical to remove all such trees as the majority are in good health and likely to be safe.

Overhead networks in all jurisdictions can be affected by seemingly healthy trees unexpectedly failing sometimes due to significant storm exposure. Accurately predicting the likelihood of individual tree failures across a largely healthy population with current industry inspection methods is not practicable and therefore an element of risk will always remain. Essential Energy and its service providers implement reasonably practicable efforts to identify and manage Fall-In Risk Vegetation.

Fall-In Risk Vegetation means visibly defective Vegetation (Vegetation that is structurally unsound including as a result of the Vegetation being dead or dying, as identified from the perspective of the Network Asset, as far as is reasonably practicable to do so), that is outside the Minimum



Vegetation Clearance Zone and which may require pruning, cutting, height reduction, or removal to obviate an unreasonable risk of the Vegetation falling, dropping, and contacting Electricity Assets during the Vegetation Management Cycle.

4.7 Overhang Risk Management Zone

Branches located above the Minimum Clearing Requirement may pose a risk of falling onto the conductors.

Requirements for managing Vegetation within the Overhang Risk Management Zone include:

- Overhanging branches are not permissible where they encroach specified minimum clearance distances.
- For LV and HV, overhang is generally permissible in urban areas where the vegetation is considered structurally sound and outside minimum clearances.
- In rural areas where 'clear to sky' already exists, this state is to be maintained.
- 'Clear to sky' (removal of all overhanging branches) is required for bare conductors in P1 rural areas and for network voltages equal to or greater than 33kV.
- 'Clear to sky' practices may be utilised in other areas as defined by Essential Energy as reasonably practicable.
- Where an Exception to the Minimum Vegetation Clearance exists, the Exception also applies to 'Clear to sky' requirements.

4.8 Vegetation Corridor Management

Vegetation corridors are applied in rural areas to mitigate bushfire risk while ensuring continuity of electricity supply. A Vegetation Corridor is the land surrounding Network Assets, in which Vegetation Treatment occurs or has previously occurred, and is either:

- a) contemplated under section 53 of the Electricity Supply Act 1995 (NSW) (Statutory Corridor); or
- b) established by an encumbrance registered on the title of land, usually to a nominated width, conferring a right onto Essential Energy to construct, operate, maintain, repair, renew, replace or upgrade electricity infrastructure (Registered Easement Corridor).

Essential Energy typically manages vegetation within the dimensions of the previously cleared vegetation corridor. Where the width of previous Vegetation Treatment is not discernible, the Vegetation Corridor outer dimension or width is equal to the lesser of:

- i) the Mature Tree Line (if discernible); or
- ii) the applicable Nominated Easement Width, as per AS/NZS 7000:2016 - Overhead line design, summarised below in Table 1.

Table 1. Corridor Clearances

Nominal voltage	Typical width of easement
low voltage <=1000 volts	15m (7.5 m each side of pole line)
11,000, 22,000 (inc. 12.7kV) volts	20m (10 m each side of pole line)
33,000 (inc. 19.1kV) volts	25m (12.5 m each side of pole line)
66,000 volts	30m (15 m each side of pole line)
132,000 volts	45m (22.5 m each side of centre line)

Essential Energy ensures Vegetation Corridors are sustainably managed, by:



- a) Considering the local environmental context and applying a custodian or stewardship mindset;
- b) Applying the practice of Integrated Vegetation Management, leveraging and promoting natural ecology and compatible land uses to create Vegetation Corridors dominated by Low-Growing Vegetation and slow-growing Vegetation species, out-competing faster and taller growing species;
- c) Transitioning Vegetation Management activities over time to be relatively low intensity, with less elevated Vegetation Pruning and minimal Mechanical Clearing required;
- d) Balancing Grow-In Risk Vegetation and Fall-In Risk Vegetation mitigation requirements with bushfire, network reliability and network safety performance;
- e) Ensuring compliance with the Minimum Vegetation Clearance Zone requirements through Pruning of compatible Vegetation and Removal of Vegetation incompatible with a reasonably practicable Pruning regime or other risk mitigation measures; and
- f) Ensuring Vegetation Management Cycles are primarily driven by Vegetation growth rates and environmental factors experienced within Vegetation Corridors.

4.9 Privately Owned Electricity Lines

Apart from some areas within the ACT, owners of private electricity lines, such as those that may be installed beyond the electricity meter box, are responsible for ensuring vegetation does not pose an electrical safety or bushfire hazard to the line. Essential Energy may inspect and manage Vegetation as per the relevant Hazard Management Cycle.

4.10 Network within jurisdictions other than New South Wales

The Essential Energy electricity network extends into small areas of Victoria, Queensland and the Australian Capital Territory (ACT). All requirements of this Vegetation Management Plan are applied within these areas unless otherwise stated.



5.0 MINIMUM VEGETATION CLEARANCE DIMENSIONS

5.1 Minimum Vegetation Clearances (in metres) for span lengths 0m to 300 m in NSW, QLD & VIC

For spans less than, or equal to, 300m in length which are located within NSW, QLD and VIC, the Minimum Vegetation Clearance Dimensions contained within Table 2 apply.

Note:

1. Distances specified are from the nearest conductor or cable and include allowance for sag and sway; the distances do not include allowance for Vegetation regrowth.
2. 0.5m is added to clearances for bare conductors in Bushfire Prone Areas.
3. For Steel SWER (12.7kV & 19.1kV) conductors use the 11-33kV Steel clearances. For other SWER conductor types (ACSR, AAAC, etc.) use 11-22kV clearance values.
4. Exceptions to Minimum Vegetation Clearances exist in some circumstances.

Table 2. Minimum Vegetation Clearances (in metres) for span lengths 0m to 300

Voltage	Conductor Type	Clearance Profile	Portion of Span	Span Length (X metres)			
				X ≤ 50	50 < X ≤ 100	100 < X ≤ 200	200 < X ≤ 300
LV	Bare Conductor	All directions from any conductor	First & Last 1/6 th	1.0	1.0	1.5	3.5
			Middle 2/3 rd			2.5	4.0
	Covered / Insulated Conductors	All directions from any conductor	First & Last 1/6 th	0.5	0.5	0.5	1.0
			Middle 2/3 rd			1.0	
11 - 22kV	Bare Conductors (not including steel)	All directions from any conductor	First & Last 1/6 th	1.5	1.5	2.0	4.0
			Middle 2/3 rd			2.5	5.0
	HV Aerial Bundled Cables (ABC)	All directions from any conductor	First & Last 1/6 th	0.5	0.5	0.5	1.0
			Middle 2/3 rd			1.0	
	Covered Conductor Thick (CCT)	All directions from any conductor	First & Last 1/6 th	1.0	1.0	1.0	1.0
			Middle 2/3 rd				
11 - 33kV	Steel Conductor	All directions from any conductor	First & Last 1/6 th	1.5	1.5	1.5	2.0
			Middle 2/3 rd			2.5	4.0
33 - 66kV	Bare Conductors	All directions from any conductor	First & Last 1/6 th	3.0	3.0	3.0	4.5
			Middle 2/3 rd			3.0	6.0
132kV	Bare Conductors	All directions from any conductor	First & Last 1/6 th	6.0	6.0	6.0	6.0
			Middle 2/3 rd			6.0	6.5



5.2 Minimum Vegetation Clearances (in metres) for span lengths 0m to 300m within the ACT

For spans less than, or equal to, 300m in length which are located within the ACT, the Minimum Vegetation Clearance Dimensions contained within Table 3 apply.

Note:

1. Distances specified are from the nearest conductor or cable and include allowance for sag and sway; the distances do not include allowance for Vegetation regrowth.
2. 0.5m is added to clearances for bare conductors in Bushfire Prone Areas.
3. Exceptions to Minimum Vegetation Clearances exist in some circumstances.

Table 3 – Minimum Vegetation Clearances (in metres) for span lengths 0m to 300m, where located within the ACT

Voltage	Conductor Type	Clearance Profile	Portion of Span	Span Length (X metres)			
				X ≤ 50	50 < X ≤ 100	100 < X ≤ 200	200 < X ≤ 300
LV	Bare or Covered Conductor	All directions from any conductor	Entire span	1.5	1.5	1.5	3.5
			Middle 2/3 rd			2.5	4.0
	Insulated Conductors	All directions from any conductor	Entire span	1.0	1.0	1.0	1.0
11 - 33kV	All conductors	All directions from any conductor	First & Last 1/6 th	2.0	2.0	2.0	2.0
			Middle 2/3 rd			2.5	4.0
66kV	All conductors	All directions from any conductor	First & Last 1/6 th	3.0	3.0	3.0	4.5
			Middle 2/3 rd			3.0	6.0
132kV	All conductors	All directions from any conductor	First & Last 1/6 th	6.0	6.0	6.0	6.0
			Middle 2/3 rd			6.0	6.5

5.3 Minimum Vegetation Clearances (in metres) for span lengths 300m to 600m within all jurisdictions

For spans greater than 300m in length, the Minimum Vegetation Clearance Dimensions contained within Table 4 apply. Note:

1. Distances specified are from the nearest conductor or cable and include allowance for sag and sway; the distances do not include allowance for Vegetation regrowth.
2. 0.5m is added to clearances for bare conductors in Bushfire Prone Areas.
3. Low Voltage (LV) spans greater than 300m in length are rare however where they exist a Minimum Vegetation Clearance distance of 4m is applied to the whole span length.
4. Spans greater than 600m are rare and are typically found traversing deep valleys with no Vegetation encroachment found midspan. For such spans, clearance distances specified for 500-600m spans are applied unless otherwise instructed by conditions contained within an engineering assessment.
5. For Steel SWER (12.7kV & 19.1kV) conductors use the 11-33kV Steel clearances. For other SWER conductor types (ACSR, AAAC, etc.) use 11-22kV clearance values.



6. Exceptions to Minimum Vegetation Clearances exist in some circumstances.

Table 4. Minimum Vegetation Clearances (in metres) for span lengths 300 m to 600 m with no current engineering assessment.

Voltage	Conductor Type	Clearance Profile	Portion of Span	Span Length (X metres)		
				300 < X ≤ 400	400 < X ≤ 500	500 < X ≤ 600
11 - 22kV	Aluminium Conductor Steel Reinforced (ACSR)	Horizontal from any conductor	First & Last 1/6 th	4.0	5.5	8.0
			Middle 2/3 rd	7.0	9.5	12.5
		Above & Below any conductor	Entire Span	5.0	5.0	5.0
33 - 66kV	Aluminium Conductor Steel Reinforced (ACSR)	Horizontal from any conductor	First & Last 1/6 th	4.5	6.0	8.5
			Middle 2/3 rd	7.5	10.0	13.0
		Above & Below any conductor	Entire Span	6.0	6.0	6.0
132kV	Aluminium Conductor Steel Reinforced (ACSR)	Horizontal from any conductor	First & Last 1/6 th	6.0	7.0	9.5
			Middle 2/3 rd	8.5	11.0	14.0
		Above & Below any conductor	Entire Span	6.5	6.5	6.5
11-33kV	Steel Conductor	Horizontal from any conductor	First & Last 1/6 th	3.5	5.0	7.0
			Middle 2/3 rd	6.0	8.5	11.0
		Above & Below any conductor	Entire Span	4.0	4.0	4.0



5.4 Fenced Assets

Fenced zone substations typically have a site-specific vegetation management plan with tailored vegetation management requirements. Standalone Power Systems (SAPS) installation sites within environmentally sensitive areas may also have site-specific plans.

Fenced asset sites, including SAPS, in Rural areas without a site-specific vegetation management plan require a Vegetation Buffer Zone of 3 metres and have no vegetation overhanging the fenced yard area. Buffer Zones are areas free of trees & woody shrub species to protect assets from the potential excessive radiant heat in a fire situation and to maintain the integrity of security fencing. Grasses and small low-flammable shrub species are acceptable.

The internal yard area of the asset should be free of all vegetation including grasses and weeds to avoid ignition from sparks that may generated from equipment within the yard.

Figure 6. Clearance dimensions for fenced assets (includes SAPS)

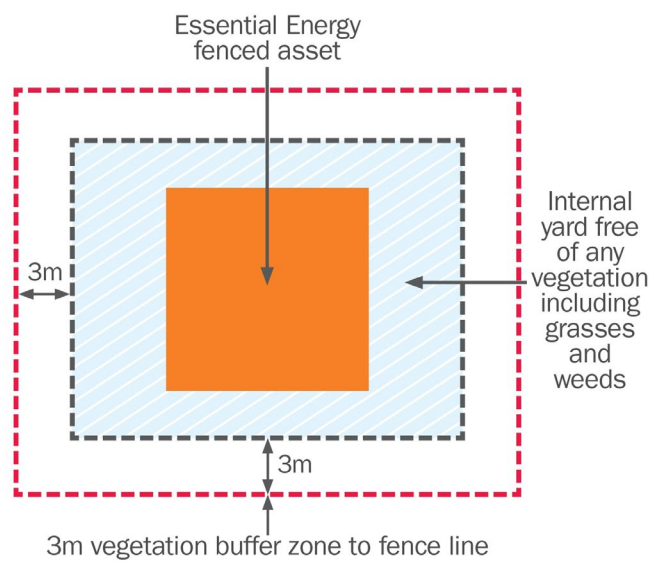

5.5 Padmount Substations and Switching Cubicles

Padmount substations and switching cubicles are typically found on road verges. No shrubs or trees are allowed within 1m to the sides of these assets, and any overhanging branches must be at least 2m above.

Figure 7. Clearance dimensions for padmount substations and switching cubicles

Padmount substations and switching cubicles are to have no trees or shrubs within 1m of the sides, and have no overhanging vegetation for at least 2m above

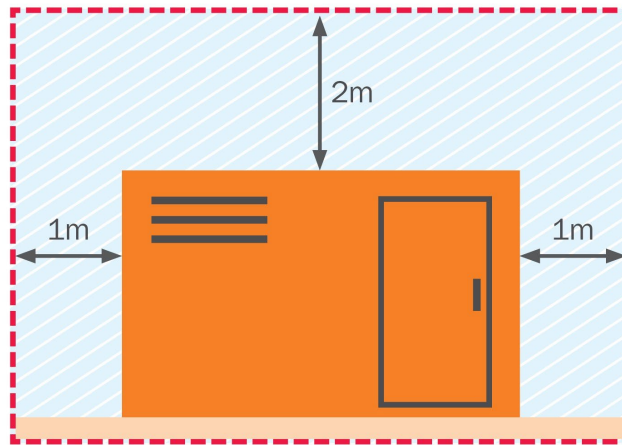

5.6 Stays, Poles and Towers

A minimum Buffer Zone of 2 metres is to be achieved in all directions around stays and poles. Transmission tower footings require a Buffer Zone of 3m in all directions.

Vegetation Treatment is undertaken on all Vegetation that is obstructing, deviating, abrading or causing damage to any stay, pole or tower, or is likely to do so, during the Vegetation Management Cycle. Damage can include, but is not limited to, reducing the effectiveness of the designed tension and insulation properties. Deep disturbance of soil is avoided.

Vegetation is trimmed to enable each pole or structure to be safely accessed from a ladder and to enable a below ground line inspection of the pole or structure to be carried out without hindrance from branches.

Branches must be pruned where necessary to prevent unauthorised access to pole steps or other pole attachments that are normally out of reach.

Figure 8. Clearance dimensions for stays poles and towers

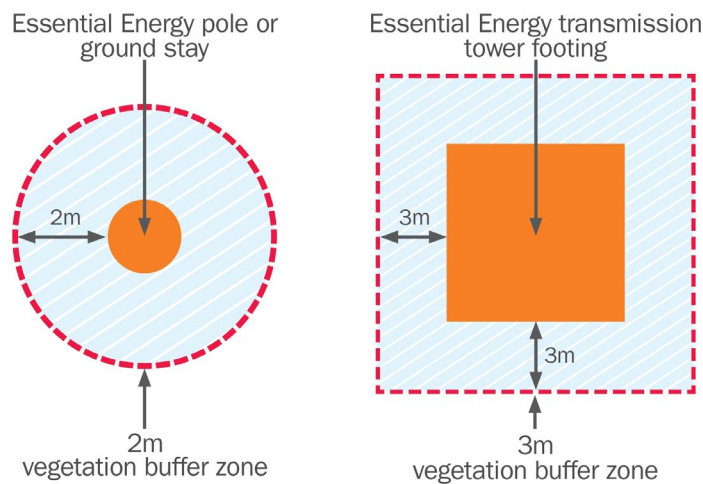

(AERIAL VIEW)



5.7 Water Crossings

All Vegetation must be cleared in front and to sides of warning signs to ensure that the entire face of a water crossing sign is visible to watercraft:

- From any point within 45 degrees from each side of the surface of the sign
- From water level to 5 metres above the surface of the water, where the sign faces the surface of the water.

Figure 9. Clearance dimensions for water crossings

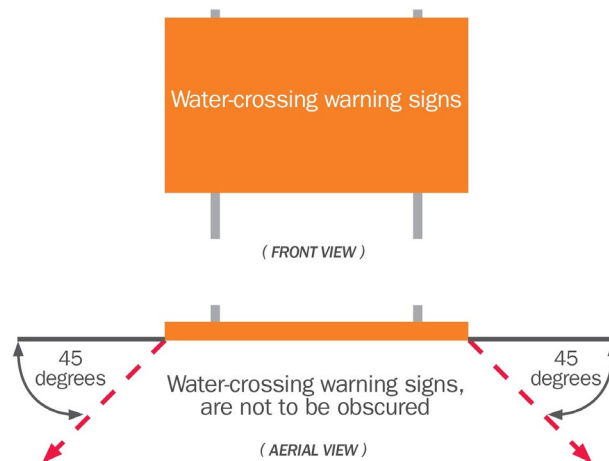

5.8 Public Lighting Clearances

Maintenance of Vegetation surrounding public lighting for the purpose of ensuring effective light egress and site illumination is the responsibility of public lighting customers.

Where public lighting is supplied electricity by an overhead cable, Essential Energy will prune Vegetation at least 2m to the sides and underneath, and 1m above, the lantern for the primary purpose of electrical safety.

Vegetation surrounding the public lighting pole is to be managed as per requirements for Poles, described in **Section 5.6 Stays, Poles and Towers**.

Vegetation clearances around public lighting (including supporting structure) supplied by underground cable is the responsibility of the public lighting customer.

Figure 10. Clearance dimensions for public lighting

Where a streetlight is supplied electricity by an overhead cable, Essential Energy will ensure vegetation is pruned at least 2m to the sides and below, and 1m above the lantern

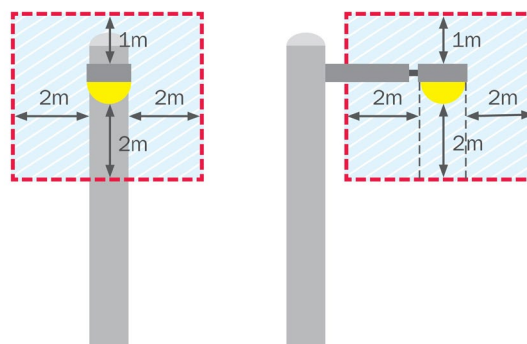

6.0 VEGETATION MANAGEMENT METHODS

Where electricity network engineering options (such as underground routing or relocation of powerlines) are not economically feasible or practical, Essential Energy employs recognised industry practices when managing vegetation. Techniques and preferred management options are determined by a qualified person conducting vegetation inspection and/or treatment.

6.1 Vegetation Inspection and Scoping

The objective of Vegetation Inspection and Scoping is to design safe, environmentally compliant, and cost-effective Vegetation Treatment solutions for managing Vegetation on or near Essential Energy Network Assets.

Vegetation Inspection and Scoping activities include but are not limited to:

- a) Identifying and recording locations of Vegetation requiring Vegetation Treatment;
- b) Proposing the Vegetation Treatment measures appropriate for each location;
- c) Determining work crew types, traffic control requirements and Plant and Equipment requirements;
- d) Notification and consultation with Landholders of Premises where identified Vegetation is located; and
- e) Identifying sensitive sites and proposing appropriate impact mitigation measures.

6.1.1 Integrated Vegetation Management

Essential Energy employs Integrated Vegetation Management (IVM) principles to determine the most appropriate vegetation treatment methods and work with the natural habits of vegetation communities to minimise long-term vegetation clearing requirements.

IVM is the practice of promoting desirable, stable, Low-Growing Vegetation communities that will resist invasion by Tall-Growing Vegetation using appropriate, environmentally sound, and cost-effective control methods.

6.1.2 Biosecurity and organic property considerations

Essential Energy manages biosecurity risks in accordance with the *Biosecurity Act 2015*, which imposes a general biosecurity duty to prevent, eliminate or minimise biosecurity risks as far as reasonably practicable. Landholders can notify persons undertaking Vegetation Inspection and Scoping of biosecurity requirements on their property, or can register the property by completing an [online form found here](#).

Landholders should also notify persons undertaking Vegetation Inspection and Scoping of any restrictions on herbicide use due to organic certification or intent to pursue organic certification.

6.1.3 Environment and heritage considerations

Persons undertaking Vegetation Inspection and Scoping activities on behalf Essential Energy identify known sensitive environmental and heritage sites and organise appropriate impact mitigation measures.

Sensitive sites include vegetation with community-recognised significance such as memorial gardens, community plantings and trees listed on heritage registers. State heritage-listed trees may require approval before pruning or may be subject to a site-specific approval exemption.

Mangroves are considered marine vegetation under the Fisheries Management Act 1994. Essential Energy has in place a permit that applies to its network area enabling the trimming and



removal of mangroves for the purposes of maintaining electricity powerlines in accordance the requirements of this Vegetation Management Plan.

Essential Energy is required to carry out vegetation works in accordance with the NSW State Environmental Planning Policy (Coastal Management) 2018. As vegetation maintenance is considered emergency or routine maintenance works, Essential Energy manages Vegetation within the coastal wetland mapped areas without triggering the need for consent.

Areas of national environmental significance are protected by the Environmental Protection and Biodiversity Conservation Act 1999 (Commonwealth) including Commonwealth lands, RAMSAR wetlands and World Heritage sites. These areas may require specific approvals before works can commence.

6.2 Pruning

Trees are pruned to arboriculture standards set forth by Australian Standard AS 4373 'Pruning of Amenity Trees' wherever practicable and in accordance with training.

The aim of the pruning is generally to work with the natural habit of each tree. The branches to be trimmed will generally be taken back to branch collars in accordance with good arboriculture practice and therefore at times may exceed the minimum vegetation clearance distance. Formative pruning techniques are generally employed to encourage the tree to grow away from the electricity network, as shown in Figure 5. Pruning must aim to not remove more than 30% of the canopy volume.

Figure 12. Illustration of formative pruning technique

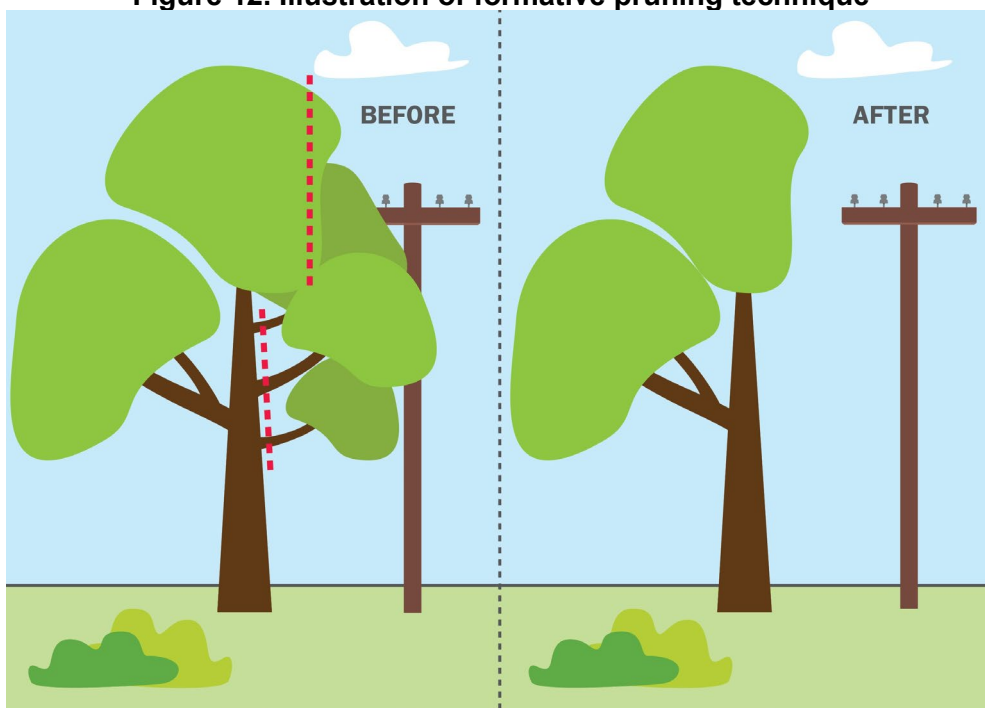

6.3 Tree Removal

Essential Energy recognises that some trees are incompatible with the extent of pruning necessary to maintain minimum vegetation clearances; where incompatible trees cannot be maintained outside the minimum vegetation clearances and where network design change is not reasonably practicable, tree removal will be pursued in collaboration with the tree owner.

Essential Energy may prioritise the removal of trees based on network risk posed by the tree and in context of other hazard rectification priorities. Where multiple trees need to be removed on the



same property or same street, Essential Energy may work with the tree owner/s to develop a phased removal plan occurring over several hazard management cycles.

At its discretion and based on available resources, Essential Energy may partially or fully fund the replacement of removed trees with a more site-suitable species.

Essential Energy will seek the removal of trees where:

- Other options including undergrounding of powerlines, replacement with aerial bundled cable (ABC), or relocation of powerlines are not economically feasible;
- The electricity works and supplies are threatened, or risk cannot be adequately managed by pruning;
- The tree cannot be pruned in a safe manner or the worksite poses unacceptable safety risk for workers;
- There is an inappropriate species imposing considerable ongoing cost to maintain;
- The tree does not respond to directional pruning away from power lines;
- The tree cannot be maintained within an appropriate Hazard Management Cycle due to growth rate;
- The health of the tree is such that to leave it would pose a threat to the electricity asset and to the safety of the community; and/or
- The aesthetics of the tree after pruning are unacceptable such that it would be more appropriate to fully remove the tree and replace with a more suitable species.

Essential Energy and its nominated service providers consider the following as examples of incompatible vegetation types likely requiring removal:

- Palms;
- Bamboo;
- Vines; and
- Trees that respond to pruning with accelerated regrowth such as;
 - Jacaranda,
 - Eucalyptus, and
 - Brush Box.

Additional examples of incompatible vegetation can be found on the Essential Energy website at www.essentialenergy.com.au/content/unsuitable-trees.

Where trees are removed the stump shall be appropriately treated to prevent regrowth.

6.4 Tree Height Reduction

Incompatible Vegetation with potential for animal habitat may be subject to height reduction instead of complete removal. Such trees are either already dead or administered with herbicide to prevent future regrowth.

Tree height reduction does not refer to, nor replace, directional Pruning or Vegetation Removal practices.

6.5 Herbicide Application

Essential Energy considers the targeted application of herbicide as an effective form of Vegetation Treatment that can allow for reduced environmental impact and foster a mix of desirable low-growing vegetation species. Suckers and saplings of tall-growing Incompatible Vegetation within the Vegetation Corridor can be treated with herbicide to prevent regrowth.

Herbicide application methods used include, but are not limited to, selective foliar spray, stem injection, cut stump spray/paste, and basal bark spray/paste. Application of herbicide must abide



by all applicable legislation, regulation, and label requirements. Efforts are taken to minimise impact on off-target vegetation.

In some instances, herbicide application may not be appropriate at the time routine vegetation treatment works are undertaken and Essential Energy or its nominated service provider may specify an appropriate follow up application period.

6.6 Vegetation growth regulators

In select circumstances Essential Energy or its service provider may use chemicals registered as plant growth regulators that slow vegetative growth by inhibiting gibberellin biosynthesis within Vegetation.

Select circumstances typically include but are not limited to Trees with significant social or economic value, which are physiologically healthy and suited to gibberellin inhibition, but otherwise cannot be safely maintained outside of the Minimum Vegetation Clearance Zone using directional Pruning methods alone. Essential Energy or its service providers will consult with the tree owner and gain tree owner approval before application of plant growth regulators.

6.7 Non-chemical applications

Herbicide application is not appropriate on certified organic properties or properties seeking such certification, where advised by the landholder. Where herbicide application is not suitable, non-chemical Vegetation Treatments such as cut-stump removal or machine-based mulching may be used. Some highly invasive species such as bamboo may require removal of the root system to prevent regrowth.

6.8 Debris management

Debris (such as pruned branches) from privately owned trees may be left in neat piles on private lands for landholders to manage, by arrangement. Mulch material that is proposed to be removed from the site and beneficially reused at another premise, must be managed and handled in accordance with a Resource Recovery Order under Part 9, Clause 93 of the *Protection of the Environment Operations (Waste) Regulation 2014 – The Mulch Order 2016*.

Debris originating from Vegetation Treatment occurring within the ACT must not be transferred to landfill sites inside or outside the ACT; such debris can be reused at another premises or deposited at locations specified by the Territory Contract Manager.

7.0 STAKEHOLDER ENGAGEMENT

Essential Energy acknowledges that activities undertaken to construct and maintain safe and reliable electricity network infrastructure are conducted on or around land managed by individuals, families, communities, agencies, or corporations. Maintaining or building trust of traditional owners and landholders is crucial to Essential Energy undertaking vegetation management activities for the purpose of ensuring electrical safety and reliability in an efficient and effective manner.

7.1 Notification

Routine vegetation management is intentionally planned to allow for sufficient time for landholder notification prior to property entry and Vegetation Treatment.



7.1.1 Notification prior to conducting routine Vegetation Inspection or Treatment

Essential Energy and its contracted service providers will attempt to make direct contact with the Landholder, either by phone or door knocking, prior to entering private premises to carry out routine Vegetation Inspection or Treatment.

A written notice of Essential Energy's intention to carry out Vegetation Treatment will also be provided to Landholders with offending Vegetation at least 2 weeks prior to commencement. Written notices may be distributed by letterbox drop or by attachment to a structure (i.e. front door, gate, or fence) close to the apparent residence or main building.

If contact with the Landholder is not able to be made at time of entry to the property, Essential Energy and its contracted service providers may proceed with Vegetation Inspection, however, only conduct Vegetation Treatment where a written notice has been provided at least 2 weeks prior.

7.1.2 Consultation on proposed Vegetation Treatment methods

Through the notification process, Landholders have an opportunity to provide reasonable instructions for access routes, timing of works and preferences for Vegetation Treatment methods such as debris mulching or stacking.

7.1.3 Urgent or Emergency Vegetation Inspection or Treatment

In an emergency, Essential Energy may exercise a power of entry at any time and without prior notice to mitigate an urgent risk or restore power supply.

So far as is reasonably practicable, Essential Energy always applies the most appropriate form of Vegetation Treatment as per the Vegetation Management Program Design and Vegetation Management Methods to ensure appropriate ongoing mitigation of vegetation related hazards.

Upon completion, the Vegetation Treatment crew will inform the relevant Landholder of the specific Emergency Work or Declared Incidents Work undertaken. Notice will also be given regarding required follow-up visit(s) to perform subsequent remedial Vegetation Treatment.

7.1.4 Written notice to give direction to undertake bushfire mitigation work

As per powers bestowed by the NSW Electricity Supply Act 1995 Essential Energy may direct a private Landholder of Bushfire Prone Land to prune or remove vegetation that could make the electricity network become a potential cause of bushfire, or otherwise fails to satisfy the requirements of this Vegetation Management Plan.

Such a direction is typically given to landholders who have recently planted trees near powerlines, as identified during the Vegetation Inspection and Scoping activity.

7.2 Landholder Queries and Complaints

Essential Energy is committed to transparency of actions and timely resolution of complaints from landholders and other interested stakeholders.

Most queries can be answered by discussing the matter with a representative of Essential Energy or its service providers whilst Vegetation Management activities are being performed.

If you wish to lodge a complaint or there is no person available on site to discuss your query with, you can use the following communication channels:

- Phone: 132 391
- Email: info@essentialenergy.com.au



- Internet: <https://www.essentialenergy.com.au/contact-us>
- Mail:
 - Customer Resolutions
 - Essential Energy
 - PO Box 5730
 - PORT MACQUARIE NSW 2444

Further information on Essential Energy's dispute resolution procedure can be found at <https://www.essentialenergy.com.au/about-us/customer-and-regulatory-information/complaints-and-dispute-resolution-procedure>

7.3 Councils

Essential Energy cooperates with Councils to ensure effective vegetation management in the best interests of the community. Plans for Vegetation Treatment are discussed with appropriate Council representatives prior to works being carried out.

Memoranda of Understanding (MOU) or "In principle" agreements are being established with Councils, where mutually supported. Such agreements provide common understanding of objectives and guide how best to manage street trees in the area.

Essential Energy consults with Council representatives prior to conducting any tree removals on Council managed land. Councils are encouraged to identify trees which they consider hazardous and notify Essential Energy where these exist within proximity of the Essential Energy network.

7.4 NSW National Parks and Wildlife Service

Vegetation control in lands reserved and dedicated National Parks will be carried out in accordance with this Vegetation Management Plan and any subsequent approval issued by the National Parks and Wildlife Service for that clearing.

7.5 Forestry Corporation NSW

Vegetation management in State Forests is carried out in accordance with this Vegetation Management Plan and Essential Energy's Forest Permit.

Heightened fire danger ratings attract restrictions on activities that Essential Energy is able to conduct within commercial plantations managed by Forestry Corporation NSW.

Essential Energy consults with Forestry Corporation NSW representatives prior to conducting Vegetation Treatment in State Forests.

7.6 Australian Rail Track Corporation and UGL Regional Linx

Where the Essential Energy electricity network traverses a railway corridor, an access permit is obtained from either Australian Rail Track Corporation Limited (ARTC) or UGL Regional Linx to ensure relevant safety measures are taken.

7.7 Australian Macadamia Society

Essential Energy maintains an agreement with the Australian Macadamia Society in relation to management of commercial plantation Macadamia trees near powerlines. The agreement sets out terms and conditions for the pruning or removal of such trees impacting on the safe operation of the network.



8.0 TREE PLANTING GUIDELINES

The right trees in the right place provide shade, privacy, wildlife habitat and help prevent erosion. The wrong trees planted near powerlines can become a safety hazard to the people and property and may impact the reliability of your power supply.

8.1 Tree planting on private land

In some instances, a property owner may be responsible for the cost of managing tree trimming or removal of trees planted close to electricity assets.

To reduce or avoid the need for tree trimming and the potential for costly tree removals, we encourage landowners to plant responsibly – please plan before you plant.

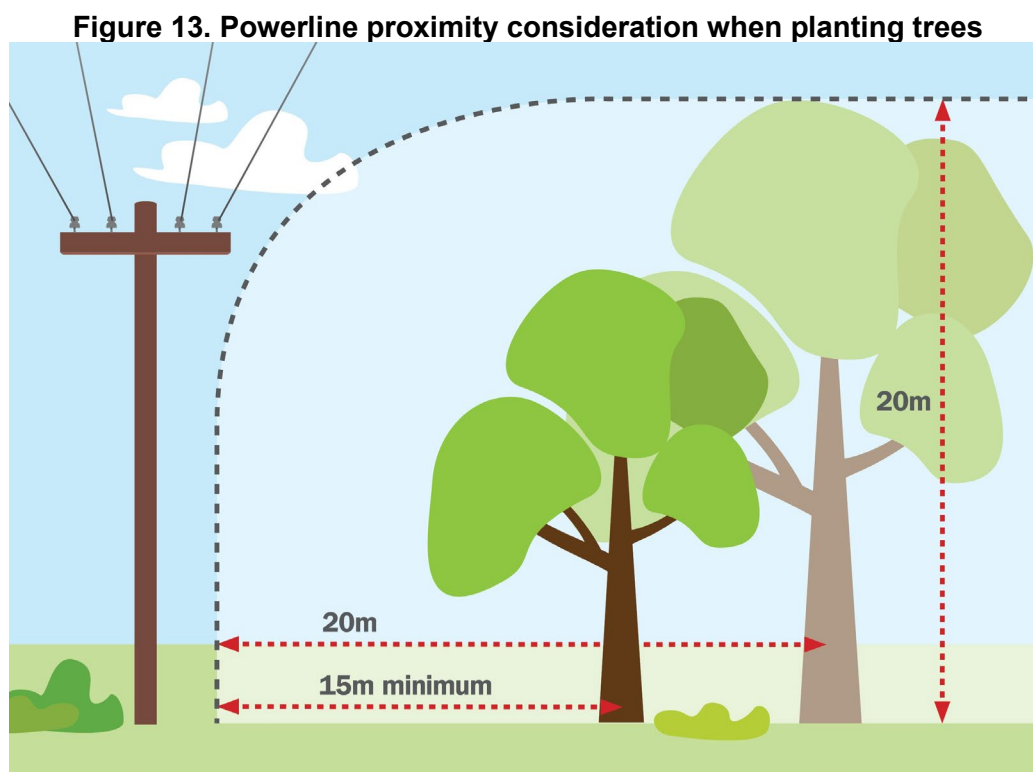

When planting, follow these guidelines:

- Always plant a tree at least 15 metres away from powerlines or a distance equal to its mature height – whichever is greater, as demonstrated in Figure 4 above.
- Do not plant large shrubs or trees under overhead service lines (the cable connecting a premise to the electricity network)
- Maintain gardens 2 metres away from any power poles, underground pits, pillar boxes and pad mount transformers.

8.2 Council (street) tree plantings

Essential Energy collaborates with Local Councils on preferred street tree species, planting locations and ongoing tree management.

Street tree planting design should consider electrical safety, with larger canopy trees planted on the opposite side of the road to overhead powerlines wherever possible.



In general, the following considerations are important when planting new street trees near powerlines:

- Only shrubs or small trees less than 3 metres tall should be planted under powerlines.
- Remember that powerlines sag and sway under hot and windy weather conditions, requiring an additional clearance space between trees and powerlines.
- Formative pruning of young trees is not the responsibility of Essential Energy, and such practices may not prevent the future need for pruning or removal if the tree grows into the Minimum Vegetation Clearance Zone.

8.2.1 Trees Unsuitable for Planting Under or Near Powerlines

Some species of trees are unable to be pruned on a reasonable frequency or are known to lose branches and impact the electricity network during strong winds. Tree types or species **unsuitable** for planting near powerlines include, but are not limited to:

- Tall palms
- Pines
- Bamboo
- Climbing vines
- Tall Eucalypts
- Fig trees
- Jacaranda
- Brush Box
- Oak
- Willow
- Ash

For more information see the [Essential Energy planting guide](#).

8.3 Commercial tree plantations (includes State Forests, private forestry, and orchards)

Commercial tree plantations pose a risk to the network, particularly during harvesting operations or from “windthrow”. The minimum agreed planting distance for powerlines through commercial tree plantations is the lesser distance of:

- 32 metres each side of pole line (64m total); or
- The maximum likely mature height of the surrounding trees (measured to nearest conductor).

9.0 AUTHORITIES AND RESPONSIBILITIES

Position / Title	Responsibility
Vegetation Strategy Manager	<ul style="list-style-type: none"> • Document owner • Strategy compliance • Strategy management
Vegetation Manager	<ul style="list-style-type: none"> • Vegetation management program delivery • Operational compliance



10.0 DEFINITIONS

- **Aerial Bundled Conductor (ABC):** A covered multi-core cable used in substitution for multiple bare single conductors.
- **Asset Protection Zone (APZ):** Is a fuel reduced area surrounding a built asset or structure. This can include any residential building or major building such as farm and machinery sheds, or industrial, commercial or heritage buildings.
- **Authorised:** Refers to being authorised by Essential Energy.
- **Bay:** The entire area between two Essential Energy structures (for example poles, towers) including the area immediately surrounding each such structure, or between an Essential Energy structure and a premises point of supply.
- **Buffer Zone:** An area free of trees & woody shrub species to maintain site access, protect assets from excessive radiant heat in a fire situation and to maintain the integrity of the asset and any security fencing. This serves the purposes of an APZ as defined by the Rural Fire Service (RFS).
- **Bushfire Danger Period:** The statutory Bushfire Danger Period is defined by the Royal Fire Service which is nominally between 1st of October to 31st March each year, however may vary from year to year and in specific locations due to local conditions.
- **Bushfire Prone Area:** Any Rural Area.
- **Bushfire Risk Priority Rating:** Is a classification of network risk derived from fire risk modelling following a Bushfire Risk assessment. The rating is applied to a Maintenance Area or Vegetation Management Area and the Assets within it.

P1 = High risk,
 P2 = Moderate risk,
 P3 = Low risk, and
 P4 = Non Bushfire prone.

Also known as Bushfire Risk Priority Indicator.

- **Clear to Sky:** The practice of clearing all Vegetation in the Overhang Risk Management Zone, to the width of the lesser of:
 - a) The Minimum Vegetation Clearance Zone plus Regrowth Allowance; or
 - b) The applicable Vegetation Corridor Width
- **Covered Conductor Thick (CCT):** CCT has a defined thickness of covering for High Voltage lines. The covering is not “touch safe” and is therefore managed the same as bare Conductors.
- **Council:** The authority of a local government area.
- **Electricity Assets:** The above ground electrical assets (including supporting and related infrastructure such as warning signs) which can be interfered with or affected by vegetation to the extent of creating a hazard. This may include assets under private or public ownership, and includes customer-owned connection assets.
- **Fall-In Risk Vegetation (commonly referred to as Hazard Tree):** Visibly defective Vegetation (Vegetation that is structurally unsound including as a result of the Vegetation being dead or dying, as identified from the perspective of the Network Asset, as far as is reasonably practicable to do so), that is outside the Minimum Vegetation Clearance Zone and which may require pruning, cutting, height reduction, or removal to obviate an unreasonable risk of the Vegetation falling, dropping, and contacting Network Assets during the Vegetation Management Cycle.
- **Hazard Management Cycle:** The length of time between performance of successive scheduled vegetation management in each VMA or Bay, which Essential Energy determines as optimal based on practical factors including vegetation regrowth rates, fire risk, climate, type of vegetation, recurrent costs, and conservation considerations.
- **High Voltage (HV):** Conductors with a nominal voltage of equal to, or greater than, 1000 volts (1kV).



- **Incompatible Vegetation:** Any vegetation requiring removal due to:
 - a) The Vegetation posing an unacceptable safety risk; and/or
 - b) The Vegetation cannot be maintained outside of the Minimum Vegetation Clearance Zone during the nominated Hazard Management Cycle, using Pruning and/or other reasonably practicable Vegetation Treatment methods, without causing ongoing deterioration of the Vegetation's health; and
 - c) Essential Energy being of the opinion that alternative methods, such as use of aerial bundled cables, relocation of powerlines, or more frequent Pruning, are not feasible (including economically feasible) in the circumstances.
- **Integrated Vegetation Management:** The practice of promoting desirable, stable, Low-Growing Vegetation communities that will resist invasion by Tall-Growing Vegetation through the use of appropriate, environmentally sound and cost-effective control methods.
- **Landholder:** Each of:
 - a) an owner, occupier, tenant, lessee or controller of a premises,
 - b) any authority having jurisdiction in connection with a premises, and
 - c) any utility or telecommunications provider providing utilities or telecommunications to a premises or having jurisdiction in connection with a premises.
- **Low-Growing Vegetation:** Any vegetation with limited potential to ever grow into the Minimum Vegetation Clearance Zone. This typically refers to, but is not limited to, Vegetation less than 3 metres in height when mature.
- **Low Voltage (LV):** Conductors with a nominal voltage of less than 1000 Volts.
- **Minimum Vegetation Clearance Zone:** The three-dimensional area surrounding Network Assets that must be maintained clear of vegetation, so far as is reasonably practicable.
- **Powerline:** An electric line, structures and equipment used for or in connection with the supply of electricity, but does not include telecommunication cables.
- **Privately Owned Electric Line:** Any overhead electric line that is the responsibility of the landholder to maintain. This typically includes overhead mains beyond the customer distribution board (commonly referred to as a meter box).
- **Rural Area:** A Vegetation Management Area or Bay classified as "Rural" within Essential Energy works management systems. This usually means areas where property road frontages are greater than 40 metres per property.
- **Sapling:** An immature tree.
- **Service Provider:** A person or company delivering Vegetation Management for Essential Energy.
- **Stand-Alone Power System (SAPS):** An independent power supply which includes solar panels, a battery for energy storage and a back-up diesel generator. It operates independently from the electricity network of poles and wires and can be used to power homes or other types of accommodation, sheds, workshops and offices.
- **Tall-Growing Vegetation:** Any Vegetation with potential to at any time grow into, or above, the Minimum Vegetation Clearance Zone. Typically refers to, but is not limited to, Vegetation which grows to a height of more than 3 metres at maturity.
- **Tree:** A plant taller than 3 metres or having a canopy more than 3 metres in diameter or having a trunk with a circumference at a height of 1 metre from the ground of more than 0.3 metres.
- **Urban Area:** A Vegetation Management Area or Bay classified as "Urban" within Essential Energy works management systems. This usually means areas where more than 5 adjacent properties have a road frontage of less than 40 metres per property.
- **Vegetation:** All living and dead plant life including, but not limited to, trees, palms, vines, shrubs, Priority Weeds, and grasses such as bamboo, but not lawns.
- **Vegetation Management:** activities undertaken to mitigate risk associated with Vegetation, and includes but is not limited to:
 - a) Vegetation Inspection and Scoping;
 - b) Vegetation Treatment;



OFFICIAL

- c) Auditing;
- d) Landholder consultation; and
- e) Road traffic control.
- **Vegetation Management Area (VMA):** A geographical area which defines a section of Essential Energy Network Assets, typically grouping Network Assets of similar environmental attributes such as Urban Area, Rural Area and/or by Bushfire Risk Priority Rating.
- **Vegetation Removal:** Practices that result in the death of the Vegetation. Such practices include, but are not limited to, tree felling, foliar spray, herbicide stem injection, and mulching.
- **Vegetation Treatment:** The activities the Service Provider must carry out and complete to treat Vegetation as part of its Vegetation Management obligations. Vegetation Treatment includes activities such as:
 - a) Pruning;
 - b) Vegetation Removal;
 - c) Mechanical Clearing;
 - d) Herbicide Treatment;
 - e) Vegetation height reduction;
 - f) Application of Vegetation growth regulators; and
 - g) Chipping, removal and disposal of by-products and debris generated by carrying out Vegetation Management.

11.0 REFERENCES

Internal
Bushfire Formal Safety Assessment CERM8047.06
Bushfire Risk Management Plan CEOP8022
Electricity Network Safety Management System CEOM8047
Vegetation Management Requirements CEOP2140
Vegetation Management ISSC3 Compliance Demonstration CECG2508.15
Company Procedure Prioritisation of Overdue Vegetation Tasks CEOP2508.16
External
Electricity Supply Act 1995 (NSW)
Electricity Supply (Safety and Network Management) Regulation 2014 (NSW)
Environmental Protection and Biodiversity Conservation Act 1999 (Commonwealth)
Protection of the Environment Operations (Waste) Regulation 2014 - The Mulch Order 2016 (NSW)
State Environmental Planning Policy (Coastal Management) 2018 (NSW)
Australian Standard AS 5577 'Electricity network safety management systems'
Australian Standard AS 4373 'Pruning of Amenity Trees'
Australian Standard AS 2067 Substations and High Voltage Installations
Australian Standard AS/NZS 7000 'Overhead line design'
ISSC3 Guide for the Management of Vegetation in the Vicinity of Electricity Assets
Code of Practice: Electricity transmission and distribution asset management 2009
Pesticides Regulation 2017 (NSW)



Rural Fires Act 1997 (NSW)
Standards for Asset Protection Zones NSW RFS
Utilities (Technical Regulation) Act 2014 (ACT)
Australian Capital Territory (ACT) Electricity (Powerline Vegetation Management) Code 2018
Electricity Act 1994 (Queensland)
Work Cover NSW Work Near Overhead Power Lines Code of Practice 2006

12.0 REVISIONS

Issue No.	Section	Details of changes in this revision	Change Risk Impact?
2 - 4	All	Minor edits	Low
5	All	Insertion of new table of powerline clearances. Various other section changes in consideration of the Black Saturday Royal Commission findings and to align with industry guidelines.	Moderate
6	All	Content expanded based on legal advice.	Moderate
7	All	Minor edits	Low
8	All	Various changes made to align vegetation management requirements with other NSW distribution network service providers.	Moderate
9	Clearance Tables	Updated to reflect changes to ISSC3	Low
10 - 12	All	Minor edits	Low
13	All	Various changes made to reflect risk-based compliance approach and vegetation management strategic direction to leverage integrated vegetation management techniques.	Moderate
14	Cover	Minor amendment. Stamp added to page 1.	Minor
15	All	Document structure revised to remove content duplication. New content added regarding risk management and vegetation management program design to better articulate connection to legislative and regulatory requirements. Environment and heritage considerations integrated into Vegetation Management Methods. Section on Stakeholder Engagement expanded to improve clarity on notification requirements and communication channels. New minimum clearing requirements and minor practice changes for network located within the Australian Capital Territory.	Moderate



16	5.8	Revision to improve clarity of responsibilities of managing vegetation clearances around public lighting.	Minor
----	-----	---	-------

